

# An ecological basis for control of the mongoose *Herpestes javanicus* in Mauritius: is eradication possible?

S. S. Roy<sup>1,3</sup>, C. G. Jones<sup>2</sup> and S. Harris<sup>1</sup>

<sup>1</sup>Biological Sciences, Woodland Road, Bristol BS8 1UG, UK. <sup>2</sup>Mauritian Wildlife Foundation, Black River, Mauritius, Indian Ocean. <sup>3</sup>Present address: Hebridean Mink Project, Central Science Laboratories, Scarasta, Isle of Harris, HS3 3HX, Western Isles, UK.

**Abstract** The mongoose (*Herpestes javanicus*) was introduced to Mauritius in 1902 to control rats and now threatens the native fauna. In the 1980s a Non-Governmental Organisation, the Mauritian Wildlife Foundation, began controlling mongooses in ecologically sensitive areas using labour-intensive grids of box-traps. As this is difficult to sustain in the long term, the ecology of *H. javanicus* on Mauritius was studied from 1997-2000 to suggest improvements to control methods and alternative techniques that could replace or augment current control methods. Using census techniques, radio-telemetry and long-term trapping, we found that mongooses are not territorial and achieved densities up to 50 animals/km<sup>2</sup> in some habitats. Home ranges varied from 0.25-1.10 km<sup>2</sup>, with no significant seasonal or sexual variation. Degraded forest, riparian and rocky habitats are the most favoured habitat types. Although mongooses consumed birds infrequently, rare predation events have a significant impact on the numbers of the endemic pink pigeon (*Columba mayeri*). We discuss how the information from the study can be used to improve the management of mongooses using current methods of trapping, how alternative control methods can be adopted to enhance control, and whether eradication is achievable.

**Keywords** Small Indian mongoose, (*Herpestes javanicus*); Mauritius; pink pigeon; endemic birds; trapping; home range; habitat use; diet; census.

## INTRODUCTION

The introduction of animals to island ecosystems often has deleterious consequences on indigenous fauna and flora (Atkinson 1996). This is particularly true if the species introduced is a carnivore with generalist feeding habits to which the native fauna is not adapted. The lesser Indian mongoose (*Herpestes javanicus*) is such a carnivore and has been introduced to many tropical oceanic islands, 70% of which fall within recently-designated biodiversity hotspot areas (Myers *et al.* 2000).

Mongooses were originally introduced to oceanic islands to control rats in sugar cane fields, but the species' ability to control rat populations is dubious as rats continue to thrive in areas where mongooses occur and can withstand a high degree of predation (Pimental 1955; Seaman and Randall 1962; Gorman 1975). At the same time, it is implicated in the decline of rare and endemic species from a wide range of taxa (Baker and Russell 1979; Honnegger 1980; Nellis and Small 1983; Nellis *et al.* 1984; Coblenz and Coblenz 1985; Jones 1988). On Mauritius, mongooses are blamed for the local extinction of Audubon's shearwater (*Puffinus l'herminieri*) (Cheke 1987), introduced game birds (Cheke 1987), and ground-based skinks (Vinson and Vinson 1969; Jones 1988).

Conservation on Mauritius is of high priority. The island falls within one of the designated biodiversity hotspot areas due to its high levels of endemism (Myers *et al.* 2000). Through human agency it has lost more than half of its vertebrate fauna and 90% of its original vegetation cover (Cheke 1987), and has gained at least thirty alien vertebrate species. In collaboration with the Government of

Mauritius, The Mauritian Wildlife Foundation (MWF) has been striving to conserve some of the rarer endemic species that still persist on Mauritius since the late 1970s (Jones and Hartley 1995). The management of invasive species is an important aspect of current conservation efforts on Mauritius, and the control of introduced predators, like the mongoose, is an important part of this programme.

Of the surviving large land birds of Mauritius, the pink pigeon requires the most management. The population size of this species was estimated at fewer than 20 wild birds

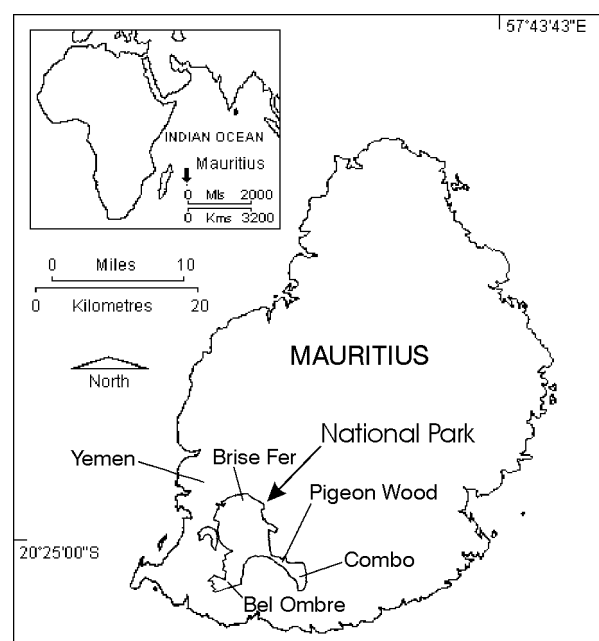

**Fig. 1** The distribution of study sites on Mauritius.

in the late 1970s (Jones 1987). Due to captive breeding and re-introduction programmes begun in the late 1980s (Jones and Swinnerton 1997), the wild population now stands at over 400 birds. Birds have been released to four mainland sites within the National Park in south-west Mauritius (Fig. 1), and to one predator free offshore island not shown on the map. These sites were chosen by MWF because they were remnant areas of high quality native forest within the National Park, which could be easily managed. The pink pigeon naturally spends a lot of time on the ground (Roy 1994) and is vulnerable to introduced ground-based predators. Long-term predator control is a crucial component of the conservation of this species.

Mongoose are currently controlled in Mauritius by using simple box traps (Fig. 2) laid out in grid systems (Fig. 3). The technique is labour intensive, and its effectiveness is unquantified. As pink pigeon populations have increased in areas that have been intensively trapped (Jones and Swinnerton 1997), it can be assumed that trapping has achieved some success as an emergency measure. However, this method was introduced as a short-term solution in the absence of any scientific data. It is clear that pink pigeon conservation will require intensive predator management in the foreseeable future. This needs to be as efficient as possible in order to be sustainable in the long-term (Safford and Jones 1998). In order to gather the information needed to make informed management decisions, we studied the ecology of *H. javanicus* on Mauritius from 1997 to 2000. The aim of this paper is to give an overview of the ecological information gained during the study and show how it can be applied to improving current management regimes. We also discuss alternatives to the current method of box-trap control and highlight how certain aspects of the ecology of the species make some alternatives more viable than others.

## METHODS

### Census techniques

We calculated relative mongoose densities from footprints collected from track stations. The track stations were set up by sieving fine sand on to bare earth in circles with a diameter of 2 m, and scented in the centre using approximately 5 ml of fish oils. These stations were grouped together in sets of four, 10 m apart, and 10 groups running

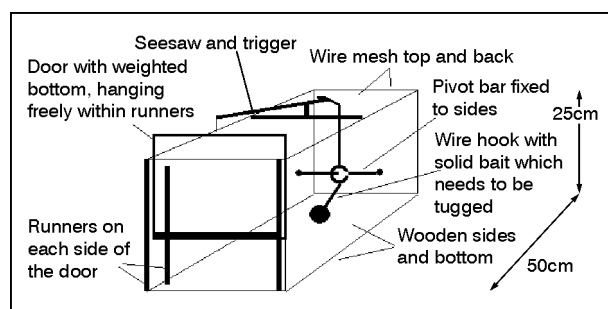

**Fig. 2** The design of traps used for mongoose control on Mauritius.

for a length of 1 km constituted a transect. Each transect was at least 5 km from its nearest neighbour, so that animals associated with one transect could not influence the number of visits recorded in another transect during the censusing periods. Transects were run for 10 days, and each day the total number of mongoose visits to each station was recorded. Track stations were re-scented and re-smoothed daily. The daily scores were treated as repeated measures over 10 days when analysed. No attempt was made to identify individuals from prints. In the analyses the total number of visits were used as an indirect measure of abundance. The number of feral cat (*Felis catus*) visits were also recorded, as other authors have found that populations of some mongoose species often interact with those of other carnivores in an ecosystem (Palomares *et al.* 1996). The census technique is an adaptation from those described by Roughton and Sweeny (1982) and Sutherland (1996).

Scent station transects were set up and run seasonally in each of the broad habitat types described by Page and D'Argent (1997) in their vegetation survey of Mauritius. These are described below:-

- Forests which largely consist of native species.
- Forests that are mostly exotic but have some native vegetation in them.
- Wholly exotic vegetation, consisting of mixed scrub, grassland and acacia forest.
- Riparian vegetation, habitats that fall within 20m either side of streams and rivers and around lake edges.
- Plantations of tea, eucalyptus and conifers.
- Sugar cane.
- Coastal vegetation.

### Radio-telemetry

Radio-tracking was carried out in Yemen (Fig. 1), a hunting estate in south-west Mauritius. This study site was chosen as it had many different habitat types within it as described above, which would highlight small-scale structural features within habitats to which animals are attracted. 14 mongooses (seven males and seven females) were caught in box traps, transferred to hessian handling sacks and immobilised by intra-muscular injection of 0.2 ml ketamine hydrochloride (Vetalar®). Animals were then collared and tracked. Collared animals were continuously followed for 10 days using the methods outlined by Harris *et al.* (1990). Radio fixes were recorded every 15 minutes, and animals were located to a 25 m by 25 m square on a grid overlaid onto habitat maps of the area. The habitats of the study area were divided into rocky areas, paths, riparian areas, sugar cane and long grass areas (>knee height), short grass areas (<knee height), mature forest, and immature forest/scrub. The habitat groupings are based on qualitative structural similarities between habitat types, for example sugar cane and long grass were grouped. All radio-tracking was carried out between sunrise and sunset, since the species is diurnal (Pimental 1955; Gorman 1979; Coblenz and Coblenz 1985). Minimum convex polygons (MCP) were estimated from the data using the program

CALHOME (Kie *et al.* 1996). Home ranges were then overlaid onto habitat maps created using the GIS package Arcview (ESRI 1996), and compositional analysis was carried out to determine habitat use by the species, as described by Aebischer and Robertson (1993).

## Long-term trapping

The predator management regimes at MWF field stations were formalised in 1997. The field station at Combo (Fig. 1) only became operational in 1999 and has not been included in the analyses. The other field stations are described as follows:

- Brise Fer: set up in 1988, this is the longest running MWF field station. It contains the largest tracts of pristine native vegetation and was the site of the first successful pink pigeon releases in the late 1980s. As a result it is also the site with the longest history of predator management. It had 24 traps.
- Pigeon Wood: this is the site where the last remaining wild pink pigeons were found. Predator management regimes began in this site in 1991. It had 23 traps.
- Bel Ombre: this field station was set up in 1994, when the pink pigeons were first introduced to it. It had 22 traps.

The placement of traps follows the general strategy described in Fig. 3. All field stations had a concurrent history of rat control (*Rattus rattus*), although in Bel Ombre rat control ceased after two years.

Traps were allocated to the following categories:

- Access traps: placed near (though not necessarily on) paths, dry riverbeds or other such entry points into pink pigeon breeding areas.
- Perimeter traps: placed in a protective ring around pink pigeon breeding areas, to stop predators entering the predator-free zone.
- Core traps: grid of traps within an area that is intensively managed to create a predator-free zone. These

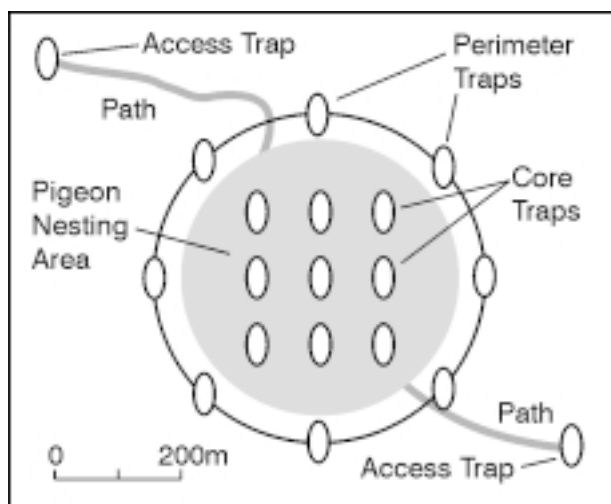

**Fig. 3** A stylised trapping grid showing how traps are set out at MWF field stations.

grids were strategically placed to coincide with areas of high pigeon breeding and nesting activity.

Various habitat features associated with these traps were recorded, and analysed with respect to mongoose trapping success. These were:

- Trap type (Access, Perimeter or Core).
- Main habitat type in a 2 m radius around the trap (rock and bare earth, ground vegetation, understorey or mature tree).
- The main habitat type in a 20 m radius around the trap (scrub and immature forest, guava thicket, mature forest).
- Linear features within a 2 m radius of the trap (none, habitat edge, path and river).

These results were then compared qualitatively to the results from compositional analysis. It should be noted that not all the habitat types recorded in the radio-tracking or census study were represented in the trapping study. This is because the trapping grids were set up as a management measure, whilst the others are part of a study directed solely to understanding the ecology of the mongoose. For example, thickets of guava are frequent in the field stations whilst in places like Yemen they are not. As a result any comparisons drawn are broad and qualitative.

## Diet

Carcasses were collected by trapping at Bel Ombre, Brise Fer, and Pigeon Wood, and in the lowland gorges around Mauritius as part of the Mauritius kestrel (*Falco punctatus*) recovery programme from 1984 to 1997. Road kills were also collected opportunistically. Animals captured in box traps were transferred to handling sacks and killed by cervical dislocation. The entire gut was removed and gut contents were washed into a 0.5 mm sieve, and contents were sorted, identified and grouped into six broad categories for statistical analysis. It was assumed that there were no major changes in the different prey groups from 1984 to 1999, the data from different years were pooled to increase sample size, and presented as percentage frequency of occurrence of prey items.

## RESULTS

### Habitat use

#### *Radio-telemetry*

Compositional analysis (Aebischer and Robertson 1993) was used to quantify the habitat use by radio-collared mongooses. This technique compares the number of radio fixes per unit area recorded in each habitat type with each of the other habitat types in turn. The total number of times a habitat is preferred over others is then summed and used to rank that habitat type. Habitat types of equal rank were then grouped together. Habitat use was found to be non-random (Wilks' lambda = 0.77,  $P < 0.001$ ), and then ranked and grouped (shown in bold) as shown below. In this example there are two clear groups; 'A' is the most preferred

habitat group while 'B' is not. As a result of this procedure some habitat types do not neatly fit into a particular rank group and have a wide "band", as shown by the "forest" habitat below:

- Rocky areas and riparian habitats (A)
- Mature forest (A, B)
- Scrub, long grass/sugar cane, short grass, paths (B)

### Trapping

A generalised linear model (GLIM) was used in Minitab (Ryan *et al.* 1985) to test whether the placement of traps had any significant effect on subsequent captures of mongooses. Traps of different categories (access, core, and perimeter) did not show significantly different capture rates for mongooses ( $F = 0.24$ ,  $P = 0.78$ ). They were subsequently pooled in order to increase sample sizes for the rest of the analyses. The habitat type 20m around the trap did significantly influence captures. Figure 4 shows that mongoose capture was higher in forest habitats than in scrub habitats. Capture rates were generally low, with an average of 0.03 mongooses/trap night in each of the field sites of Bel Ombre, Brise Fer, and Pigeon Wood. This was partly due to capture of non-target species, such as tenrecs (*Tenrec eucaudatus*), introduced from Madagascar.

The sex ratio as shown by trapping was male biased, ranging from 3:1 to 5:1. It is assumed that this was not a result of sexual bias in trapability, as data from other trapping studies in Mauritius not presented here show a 1:1 sex ratio. Instead, this is probably caused by immigration into areas where mongooses have been removed by trapping. In many small carnivore species, males show a greater tendency to disperse than females, and the same may be true for mongooses, as reported by other authors (Hoagland *et al.* 1989).

### Census

A GLIM model was run in Minitab (Ryan *et al.* 1985) to relate the effects of cat visitation, season, and habitat type on mongoose visitation rates. Interactions between these

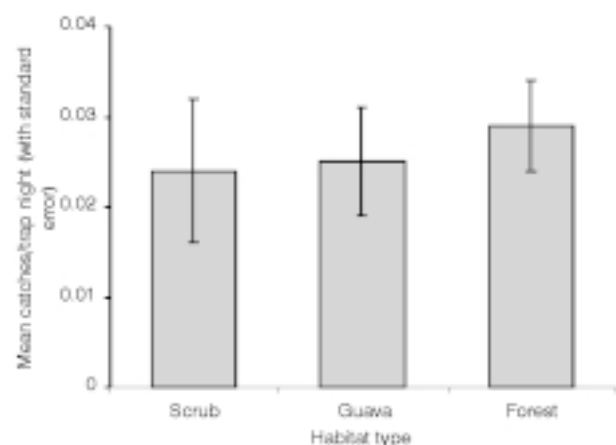

**Fig. 4** The effects of habitat in a 20m radius around traps on capture success (GLIM: Habitat type;  $DF=2$ ,  $F=2$ ,  $P<0.05$ ).

factors were also tested. A deletion test was carried out where non-significant factors and interactions were removed from the model and the test was repeated until only significant factors and interactions were left. Mongoose visitation varied significantly in different habitats, and in different seasons. There was also a season-habitat interaction suggesting seasonal movement between habitat types ((1) Habitat;  $DF = 6$ ,  $F = 55.30$ ,  $P<0.001$ ) (2) Season;  $DF = 2$ ,  $F = 15.82$ ,  $P<0.001$ ) (3) Season-habitat;  $DF = 12$ ,  $F = 5.19$ ,  $P<0.001$ ). Mongoose visitation rates were highest in degraded forest and riparian habitats, and lowest in coastal habitats and sugar cane. Visits by feral cats had no effect on mongoose visits ( $DF = 1$ ,  $F = 0.10$ ,  $P = 0.753$ ).

### Territoriality

Males' and females' ranges did not differ significantly ( $N = 14$ ,  $F = 1.48$ ,  $P = 0.28$ ), although this is based on a small sample size. The mean MCP home range size ( $\pm$  standard error) was  $0.77 \pm 0.07$  km<sup>2</sup> and ranged from 0.25km<sup>2</sup> to 1.10km<sup>2</sup>. Density estimates from capture-mark-recapture in these areas ranged from 25.6 to 52.4 animals/km<sup>2</sup> (mean 37.3). Home ranges overlap considerably and the species is not territorial. During other trapping studies on Mauritius individual traps caught up to six different animals (marked with ear tags) within the space of a week. This supports earlier findings that *H. javanicus* is not a territorial species (Gorman 1979). Populations in small areas had rapid turn over, and during trapping studies, animals caught and tagged in one season were not caught in the next trapping session three months later. This is more likely to be a consequence of seasonal movements rather than induced trap-shyness. Evidence to support this is borne out by the fact that animals that had been radio-collared or ear-tagged were caught on several occasions after their initial capture, while the census studies described above have shown that populations show seasonal movements between habitat types. Subsequent modelling (Roy 2001) showed that mongoose populations are more sensitive to changes in survival than to changes in fecundity.

### Diet and impact on pink pigeon populations

A total of 458 mongoose guts (365 male and 93 female) were analysed. The frequency of occurrence of all main prey groups is presented in Table 1. Birds were the least

**Table 1** The frequency of occurrence of different food types in 458 mongoose guts collected from 1986 to 1999.

Prey type	Frequency of mongoose guts with food type (%)
Rodents and shrews	46
Tenrecs	20
Invertebrates	20
Refuse, carrion, and plant material	18
Reptiles and amphibians	15
Birds	6

frequent of all prey items and only occurred in 6% of guts, while rodents and shrews were the most frequent and occurred in 46% of the guts examined. Despite this low incidence of bird predation we believe that mongooses do have an impact on pigeon populations. To support this a time series multiple regression was carried out using the data from Brise Fer, a site with the longest history of predator management. This analysis showed that pink pigeon mortality correlated significantly negatively, albeit weakly, with increased numbers of mongooses trapped and removed from the period 1996-1999 ( $r^2 = 18\%$ ,  $P = 0.012$ ) (Roy 2001).

## DISCUSSION

### The long-term management of mongooses

Mongooses in Mauritius will have to be managed for a long time into the future. Mauritius is too large, and current technology is too limited, for any attempts at eradication of this widespread introduced species. However, larger areas need to be managed for conservation to be more effective. Firstly, larger reserves improve the long-term chances of survival of native species (MacArthur and Wilson 1967). Secondly, populations of animals, in particular carnivores, are more predictable in larger areas rather than smaller areas, making their management easier (Smallwood 1999). Therefore the management of mongooses over larger areas should be a primary goal in the future. Control of other invasives often involves techniques that have been developed by adapting existing knowledge from gamekeeping or agricultural protocols. This is illustrated by the stoat (*Mustela erminea*); many of the control methods and equipment used for managing this species in New Zealand are based on European gamekeeping techniques (Reynolds and Tapper 1996). Mongooses, however, have very little long-term cultural history of control. In order to control mongooses on islands, the favoured way is trapping, mostly using Tomahawk or box traps (Coblentz and Coblentz 1985). These techniques are too labour intensive for use over large areas, but they can be improved if we take into consideration some of the findings from the study. The improvements are presented as follows:

#### Trap spacing

The smallest home range was found to be 0.25 km<sup>2</sup> so it is recommended that the minimum trap density should be one trap every 0.25 km<sup>2</sup>. However, home ranges were seen to overlap greatly and animals were not seen to be territorial, so a greater trap density than this is preferable. Further experimentation with trap spacing and different bait types is needed to show if the trapping biases discussed earlier are a true indication of the sex ratio of the mongoose population or an artefact of trap shyness of females. Placing more than one trap at each trap site should improve the number of captures a night. This is because currently traps can only catch one animal a night and often traps become temporarily inoperative due to capture of

non-target animals such as tenrecs. As mongooses are not territorial, it can be assumed that there is a likelihood of more than one animal being present over a small area at any one time.

#### Trap siting

Forested habitats feature highly in the habitat preferences of mongooses as shown by radio tracking. Long-term trapping studies also show that traps in forested habitats are more successful, while census studies show that the highest densities of mongooses occur in degraded forest. It is clear that control should focus on this habitat type, especially where resources are limited.

#### Predator control in a multi-predator environment

Only 6% of mongoose guts had bird remains in them. A low level of predation can still affect the long-term survival of pink pigeon populations. Predator control should be concentrated in areas frequented by species of conservation concern. It should also be noted that 46% of mongoose guts had rodent and shrew remains in them. Controlling just mongooses on their own may release rats from predation pressure, and may also release feral cats from feeding competition. As cats and rats are also major bird predators, mongoose trapping should be carried out as part of a regime that targets all of the predator species together. Further research on the interaction between the different predator species is required to allocate resources optimally between the different predator species.

### Alternative control measures that could be adopted in future

Long-term predator control over larger areas is possible if we adopt alternative, less labour-intensive approaches to control, as it is clear that this is not possible by trapping alone. These alternatives could be used for large-scale management, possibly combined with small-scale intensive trapping regimes at particularly vulnerable locations. The ecology of mongooses on Mauritius, and of species of conservation concern, favours some control methods over others. These are discussed below:

#### Non-lethal physical techniques

*Barriers:* Fencing and placing metal barriers on trees may prevent mongooses from reaching sensitive areas or nests respectively as the species does not climb very well. Fencing may not be an option, however, as it is a costly technique and would require a lot of maintenance in a country like Mauritius which frequently suffers cyclones. Also, Mauritius has other introduced predators that do climb well, such as the macaque (*Macaca fascicularis*), and such barriers would not prevent predation by these species. If fencing is to be used, the construction should prevent predation by all major introduced predators, especially as it is so costly. Fencing is also an inflexible approach to predator management. Once erected, it would not be easy to

respond to changes in the boundaries of conservation management areas through regeneration and recovery; a scenario which is likely to occur on Mauritius as pink pigeon populations expand as the forest recovers. Fencing is not a viable alternative at its current cost. Should the cost decline in future, sensitive areas may be eradicated of ground-based predators by trapping or poisoning, fenced, and ingress of predators prevented by monitoring and preventative measures around the boundaries to help prevent re-entry into enclosed areas.

**Habitat management:** Hitherto the promotion of unfavourable habitats to reduce mongoose populations or create unfavourable hunting conditions has had mixed results (Alterio *et al.* 1998). Radio-collared mongooses spent less time in open areas of short grassland than in any other habitat and they may also be den-site limited (Roy 2001). So removing denser ground vegetation in pink pigeon feeding areas and removing potential den sites may be beneficial in combination with other management practices.

### **Non-lethal chemical techniques**

**Fertility control:** Reducing the fertility of mongooses via baits placed in the field is not an option as the technology has yet to be developed. Also, the pink pigeon populations around Mauritius are at a stage where any short-term predation is likely to affect the survival of the population and sterile mongooses could still prey upon pink pigeons in the short term. There would also be no guarantee of reaching every animal, especially as immigration rates of fertile animals are potentially quite high in some habitat types.

**Conditioned taste aversion:** By placing chemically-altered foul-tasting prey items in the environment, predators can sometimes be “trained” to avoid that particular prey type. The technique has been used to reduce fox predation on the eggs of ground-nesting birds (Conover 1990). However, mongooses are not the ideal predator for this technique as they are short-lived with a high population turnover through recruitment and immigration. There is a constant influx of “untrained newcomers” into the environment and each animal has only a limited exposure to the foul-tasting bait. This is not a viable alternative to current control methods.

### **Lethal methods**

**Alternative trap types and baits:** There are many alternative trap types available on the market, such as Fenn traps, but the costs of these far exceed those of the home-made traps employed in Mauritius. Using them would greatly add to the expense of control operations, making them unsustainable in the long term. Also, the traps currently used present no danger to native birds and are easy to operate by volunteers with minimal training. This is not the case with some of the other traps available on the market. The current trap type can be improved, however, by making them from standardised parts that are easy to assemble and dismantle so that field operators can replace trap parts rather than whole traps as part of their maintenance.

**Poisoning:** Mongooses are poisoned successfully in Hawaii with diphacinone (Lindsay and Mosher 1994; Dusek and Aeder 1995), a poison to which they appear to be very susceptible. Baits placed in the environment have a high probability of being taken as *H. javanicus* has been shown to take baits readily (Creekmore *et al.* 1994).

Of all the alternatives outlined, poisoning is the most viable in the near future. However, poisoning campaigns often affect non-target species, and if the dosage of poisons within bait formulations is species specific, large non-target species such as cats may not be killed quickly and humanely, raising ethical issues. Poisoning campaigns can be made more species specific using the “Achilles’ heel” approach (C. Marks pers. comm.). This approach uses physiological, ecological and behavioural attributes unique to a species to improve the species specificity of a poisoning campaign, for example by placing poison baits in rock crevices the baits can be made more accessible to mongooses and less accessible to feral pigs or monkeys. This approach is already being used to develop baiting campaigns for foxes (Busana *et al.* 1998) and feral cats (Fisher *et al.* 1999) in Australia. It increases efficiency and minimises bait uptake by native marsupial carnivores (Belcher 1998), and field trials using bait markers, which show up in the whiskers or the blood of captured animals, are being used to evaluate the specificity of bait delivery methods (Fisher *et al.* 1999). Similar poisoning campaigns for mongooses would need to exploit behaviours unique to mongooses to reduce uptake by non-target species. For example, typical mongoose den sites could be targeted with bait delivery stations. However, for generalist, opportunistic species like mongooses, there are few “unique” food preferences that could be exploited to prevent uptake by opportunistic non-target species such as insects, which could then be eaten by native insectivorous birds like the merle (*Hypsepetes olivaceus*). With a better understanding of its autecology, it may be possible to identify the mongooses’ “Achilles’ heel”. This will facilitate the development of efficient, species-specific control programmes.

An alternative to the Achilles’ heel approach is to formulate poisons, or use mixed baits so that they quickly kill multiple target species (i.e. cats, rats and mongooses). Controlling multiple predators may be a better control strategy where there is a risk of meso-predator release as a result of single species control. The situation on Mauritius also favours this approach because, unlike Australia, there are no native mammals that could be affected by toxicants in poison baits, and all three predators are believed to have a significant impact on native species.

## **The future of mongoose control in Mauritius; is eradication ever possible?**

Mauritius has an area of approximately 2000 km<sup>2</sup> and is densely populated with a population of 1.5 million people. It has a large mongoose population throughout the island, some areas of which are very mountainous and rela-

tively inaccessible. Mongooses may be controlled or even eradicated in the distant future with the use of aircraft to drop poison bait formulations, along with the co-ordinated efforts of different government departments and authorities, but this is unlikely in the near future due to lack of resources. Further study is required to test poison bait uptake in the field using bait-marking studies similar to those described earlier. Also bait formulations need to be optimised to ensure that they do not pose a risk to non-target species, before poisons are broadcast over large areas.

In the short term mongooses can be more efficiently controlled or even eradicated over small, sensitive areas with conservation value using trapping in combination with poisoning. In conjunction with this, mongooses can be controlled over large buffer areas by poisoning. This would achieve control over a large area and reduce immigration into sensitive core areas. The poison could be delivered using bait delivery stations or it could be placed by hand at bait points as long as safety issues are addressed and field trials on bait uptake are carried out.

Any improvements in ecological management of *H. javanicus* will require a greater understanding of its ecology, and this requires more information on the population and behavioural ecology of the species in both its native and introduced range. In particular, we need to investigate the uptake of baits in the field and the interactions between mongooses and other predator species. If management regimes can be made more cost-effective and efficient, in time larger areas could be managed. The work on Mauritius carried out so far adds to our knowledge of the species, and can be applied to other islands where the species has not been studied.

In this respect, Mauritius is an ideal site for such a study. It is a typical, tropical oceanic island with all of the problems faced by other islands, such as habitat loss and introduced species. It is a biodiversity hotspot, and much of its flora and fauna is well studied and has been well recorded in history. Very simple conservation techniques have been used to save some of the world's rarest species, like the Mauritius kestrel, which has been restored to a state where the population is self-sustaining or requires minimal management (Jones *et al.* 1995). Mongoose control played a significant role in conserving the Mauritius kestrel. Conservation techniques are easier to develop on Mauritius than on other islands where the fauna and flora or the geography have not been as well studied. Techniques developed on Mauritius can in future be adapted and applied to other, lesser-studied island ecosystems, where other conservation issues need to be addressed.

## ACKNOWLEDGMENTS

We would like to thank the staff and volunteers of MWF and the National Parks and Conservation Service of Mauritius for their assistance in the field. We would also like to thank the managers of the Yemen Hunting Estates for

access to their lands. S. Carter and P. Baker made helpful comments on the manuscript. The Dulverton Trust and the Mauritian Wildlife Foundation funded this project.

## REFERENCES

- Aebischer, N. J. and Robertson, P. A. 1993. Compositional analysis of habitat use from animal radio-tracking data. *Ecology* 74: 1313-1325.
- Alterio, N.; Moller, H. and Ratz, H. 1998. Movements and habitat use of feral house cats *Felis catus*, stoats *Mustela erminea* and ferrets *Mustela furo*, in grassland surrounding yellow-eyed penguin *Megadyptes antipodes* breeding areas. *Biological Conservation* 83: 187-194.
- Atkinson, I. A. E. 1996. Introductions of wildlife as a cause of species extinctions. *Wildlife Biology* 2: 135-141.
- Baker, J. K. and Russell, C. A. 1979. Mongoose predation on a nesting nene. *Elepaio* 40: 51-52.
- Belcher, C. 1998. Susceptibility of the tiger quoll, *Dasyurus maculatus*, and the eastern quoll, *D. viverrinus*, to 1080-poisoned baits in control programmes for vertebrate pests in eastern Australia. *Wildlife Research* 25: 33-40.
- Busana, F.; Gigliotti, F. and Marks, C. 1998: Modified M-44 cyanide ejector for the baiting of red foxes (*Vulpes vulpes*). *Wildlife Research* 25: 209-215.
- Cheke, A. 1987. An ecological history of Mauritius. In Diamond A.W. (ed.). *Studies of Mascarene Island Birds*, pp. 5-89. Cambridge, Cambridge University Press.
- Coblentz, B. E. and Coblentz, B. A. 1985. Control of *H. auropunctatus* on St John, US Virgin Islands. *Biological Conservation* 33: 281-288.
- Conover, M. R. 1990. Reducing mammalian predation on eggs by using a conditioned taste aversion to deceive predators. *Journal of Wildlife Management* 54: 360-365.
- Courchamp, F.; Langlais, M. and Sugihara, G. 1999. Cats protecting birds: modelling the mesopredator release effect. *Journal of Animal Ecology* 68: 282-292.
- Creekmore, T. E.; Linhart, S. B.; Corn, J. L.; Whitney, M. D.; Snyder, B. D. and Nettles, V. F. 1994. Field-evaluation of baits and baiting strategies for delivering oral vaccine to mongooses in Antigua, West-Indies. *Journal of Wildlife Diseases* 30: 497-505.
- Crooks, K. R. and Soulé, M. E. 1999: Mesopredator release and avifaunal extinctions in a fragmented system. *Nature* 400: 563-566.
- Dilks, P.; O'Donnell, C. F.; Elliott, G. P. and Phillipson, S. M. 1996: Effect of bait type, tunnel design and trap position on stoat control operations for conservation management. *New Zealand Journal of Zoology* 23: 295-306.
- ESRI 1996. Using ArcView GIS. Environmental Systems Research Institute, Inc. USA.

- Fisher, P.; Algar, D. and Sinagra, J. 1999. Use of Rhodamine B as a systemic bait marker for feral cats (*Felis catus*). *Wildlife Research* 26: 281-285.
- Gorman, M. 1975. The diet of feral *H. auro punctatus* in Fijian islands. *Journal of Zoology, London* 175: 273-278.
- Gorman, M. 1979. Dispersion and foraging in the small Indian mongoose relative to the evolution of social viverrids. *Journal of Zoology, London* 187: 65-73.
- Harris, S.; Cresswell, W. J.; Forde, P. G.; Trehwella, W. J.; Woollard, T. and Wray, S. 1990. Home-range analysis using radio-tracking data - a review of problems particularly applied to the study of mammals. *Mammal Review* 20: 97-123.
- Hoagland, D. B.; Horst, G. R. and Kilpatrick, C. W. 1989. Biogeography and population ecology of the mongoose in the West Indies. *Biogeography of the West Indies 1989*: 6111-6134.
- Honegger, R. E. 1980. List of amphibians and reptiles either known or thought to have become extinct since 1600. *Biological Conservation* 19: 141-58.
- Jones, C. G. 1987. The larger land birds of Mauritius. In A. W. Diamond (ed) *Studies of Mascarene Island birds*, pp. 209-300. Cambridge, Cambridge University Press.
- Jones, C. G. and Hartley, J. 1995. A conservation project on Mauritius and Rodrigues: an overview and bibliography. *Dodo, Journal of the Wildlife Preservation Trusts* 31: 40-65.
- Jones, C. G. and Swinnerton, K. J. 1997. A summary of conservation status and research for the Mauritius kestrel *Falco punctatus*, pink pigeon *Columba mayeri* and echo parakeet *Psittacula eques*. *Dodo, Journal of the Wildlife Preservation Trusts* 33: 72-75.
- Jones, C. G. 1988. A note on the Machabee skink with a record of predation by the lesser Indian mongoose. *Royal Society of Arts and Sciences, Mauritius* 5: 130-133.
- Jones, C. G.; Heck, W.; Lewis, R. E.; Mungroo, Y.; Slade, G. and Cade, T. 1995. The restoration of the Mauritius kestrel *Falco punctatus* population. *Ibis* 137: 173-180.
- Kie, J. G.; Baldwin, J. A. and Evans, C. J. 1996. CALHOME: A program for estimating animal home ranges. *Wildlife Society Bulletin* 24: 342-344.
- Lindsay, G. D. and Mosher, S. M. 1994. Tests indicate minimal hazard to 'Io from diphacinone baiting. *Hawaii's Forest and Wildlife* 9: 1-3.
- MacArthur, R. H. and Wilson, E. O. 1967. *The theory of island biogeography*. New Jersey, Princeton University Press.
- Myers, N.; Mittermeier, R. A.; Mittermeier, C. G.; daFonseca, G. A. B. and Kent, J. 2000. Biodiversity hotspots for conservation priorities. *Nature* 403: 853-858.
- Nellis, D. W. and Small, V. 1983. Mongoose predation on sea turtle eggs and nests. *Biotropica* 15: 159-160.
- Nellis, D. W.; Dewey, R. A.; Hewitt, M. A.; Imsand, S. and Philibosian, R. 1984. Population status of zenaida doves and other columbids in the Virgin islands. *Journal of Wildlife Management* 3: 889-894.
- Page, W. and D'Argent, G. 1997. A survey of the vegetation of Mauritius (Unpublished report, Royal Botanic Gardens, Kew).
- Palomares, F.; Ferreras, P.; Fedriani, J. M. and Delibes, M. 1996. Spatial relationships between Iberian lynx and other carnivores in an area of south-western Spain. *Journal of Applied Ecology* 33: 5-13.
- Pimentel, D. 1955. Biology of the Indian mongoose in Puerto Rico. *Journal of Mammalogy* 36: 62-68.
- Reynolds, J. C. and Tapper, S. C. 1996. Control of mammalian predators in game management and conservation. *Mammal Review* 26: 127-156.
- Roughton, R. D. and Sweeny, M. W. 1982. Refinements in scent-station methodologies for assessing trends in carnivore populations. *Journal of Wildlife Management* 46: 217-229.
- Roy, S. S. 1994. Spatial and temporal habitat use in pink pigeons, *Columba mayeri*, at different stages of release on the island of Ile Aux Aigrettes, Mauritius, and the implications for management. Unpublished M.Sc. thesis, Imperial College, University of London, London.
- Roy, S. S. 2001. The ecology and management of the lesser Indian mongoose *Herpestes javanicus* in Mauritius. Unpublished PhD thesis, University of Bristol, Bristol.
- Ryan, B. F.; Joiner, B. I. and Ryan, T. A. 1985. *Minitab handbook*. Boston, PWS-Kent.
- Safford, R. J. and Jones, C. G. 1998. Strategies for land-bird conservation on Mauritius. *Conservation Biology* 12: 169-176.
- Seaman, G. A. and Randall, J. E. 1962. The mongoose as a predator in the Virgin Islands. *Journal of Mammalogy* 43: 344-345.
- Smallwood, K. S. 1999. Scale domains of abundance amongst species of mammalian Carnivora. *Environmental Conservation* 26: 102-111.
- Stone, C. P.; Dusek, M. and Aeder, M. 1995. Use of an anticoagulant to control mongooses in Nene breeding habitat. *Elapio* 54: 73-78.
- Sutherland, W. J. 1996. *Ecological census techniques*. Cambridge, Cambridge University Press.
- Vinson, J. and Vinson, J. M. 1969. The saurian fauna of the Mascarene Islands. *The Mauritius Institute Bulletin* 6: 203-320.